



WIGGIN MEANS PRECAST CO., INC.

P.O. BOX 1507 POCASSET, MASSACHUSETTS 02559

TEL: 508.564.6776 FAX: 508.564.6770

www.wigginprecast.com

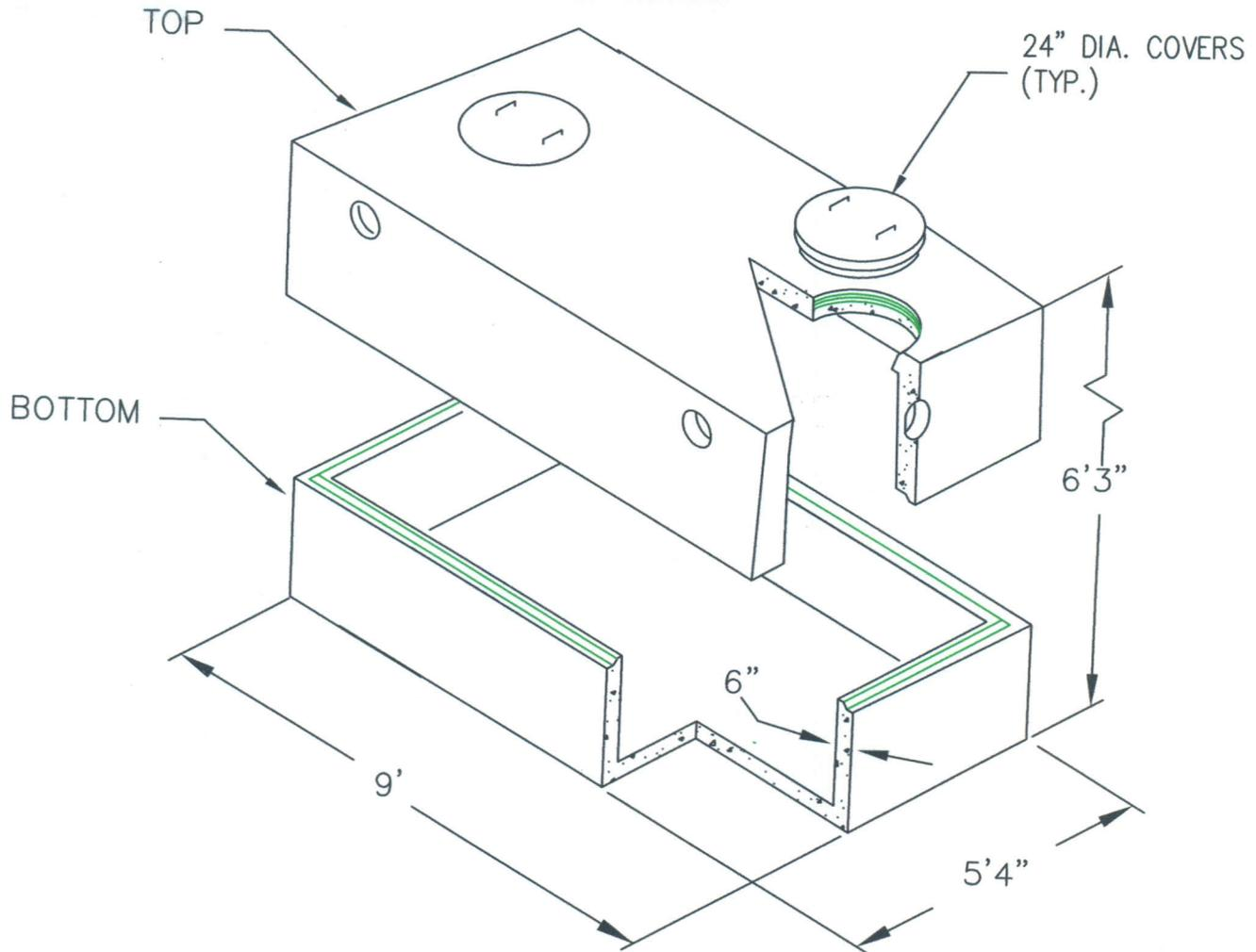

**1,000 GALLON H-20
GREASE TRAP**

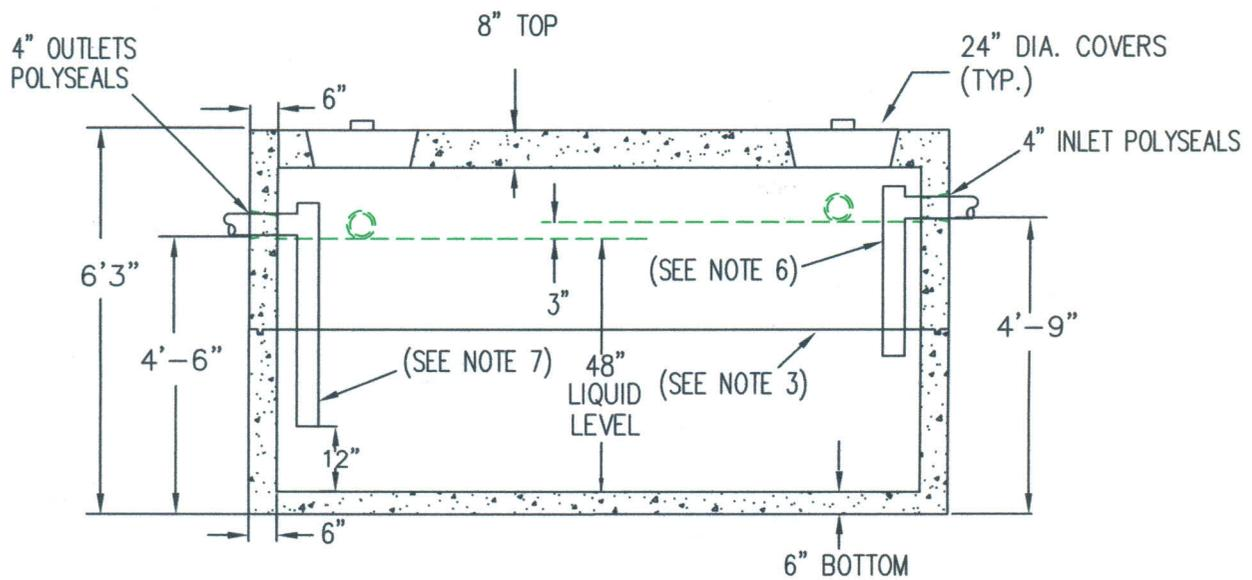
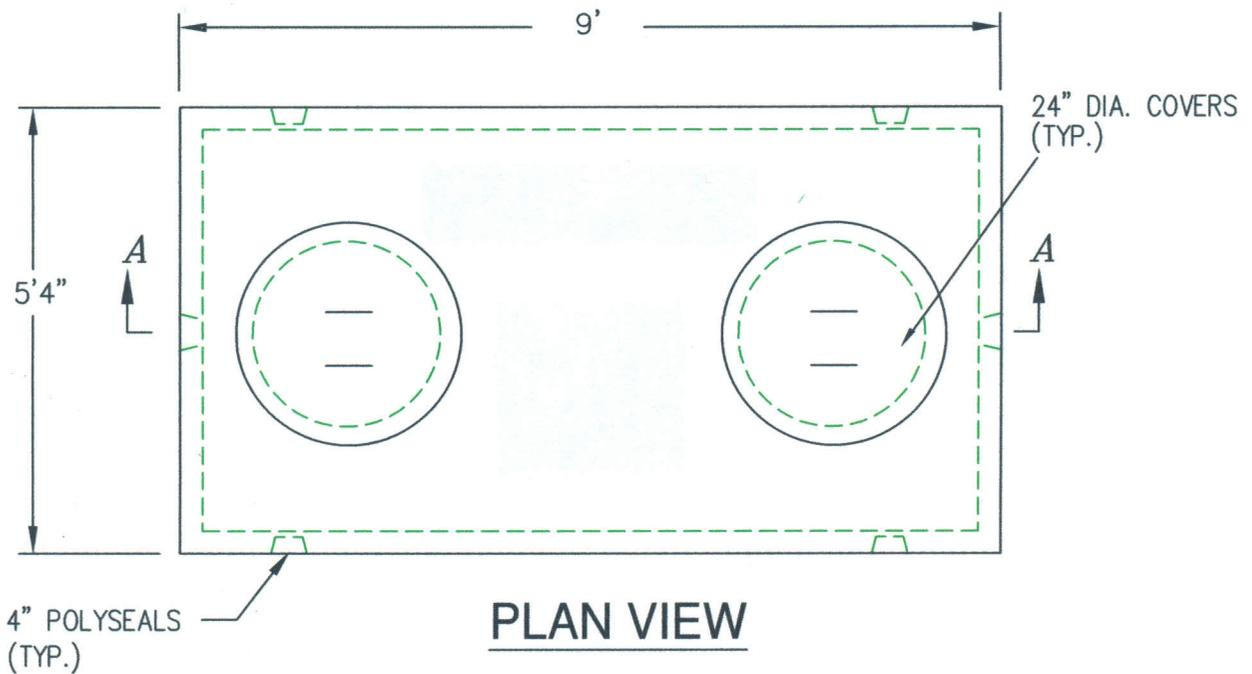

SPECIFICATIONS

- 1.) CONCRETE 5,000 PSI AFTER 28 DAYS.
- 2.) CONSTRUCTION CONFORMS TO DEP TITLE V REGS. 310 CMR SECTION 15.226.
- 3.) TONGUE & GROOVE JOINT SEALED W/ BUTYL RESIN
- 4.) REINFORCEMENT PER ASTM C1227-93.
- 5.) DESIGN LOADING AASHTO HS20
- 6.) INLET TEE SHALL EXTEND TO THE MID DEPTH OF THE TANK(TEES BY OTHERS)
- 7.) OUTLET TEE SHALL EXTEND TO 12" TO BOTTOM OF TANK(TEES BY OTHERS)

Weight 16,575 #