



WIGGIN MEANS PRECAST CO., INC.

P.O. BOX 1507 POCASSET, MASSACHUSETTS 02559

TEL: 508.564.6776 FAX: 508.564.6770

www.wigginprecast.com

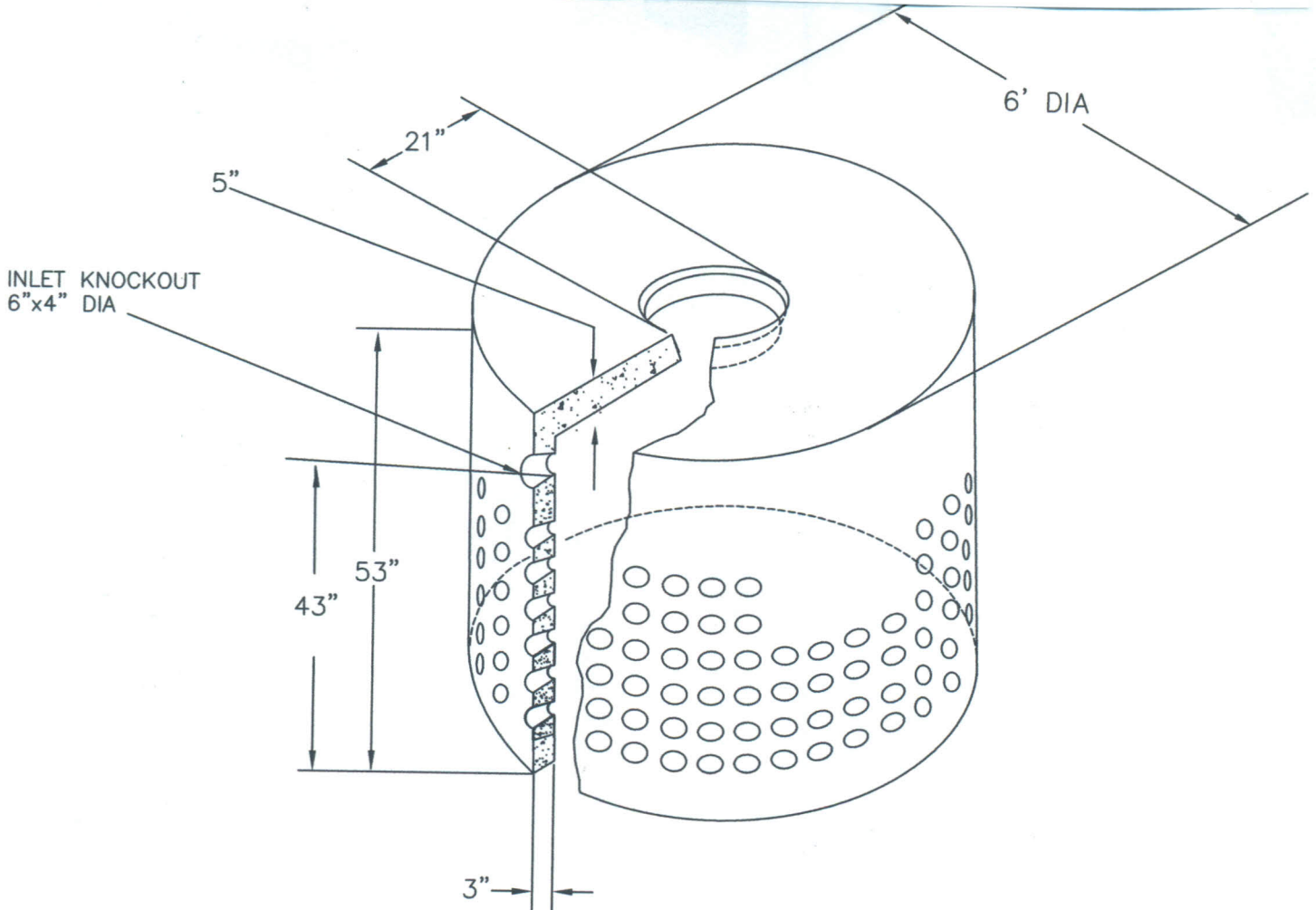

600 GALLON LEACH PIT

H-10

LP600

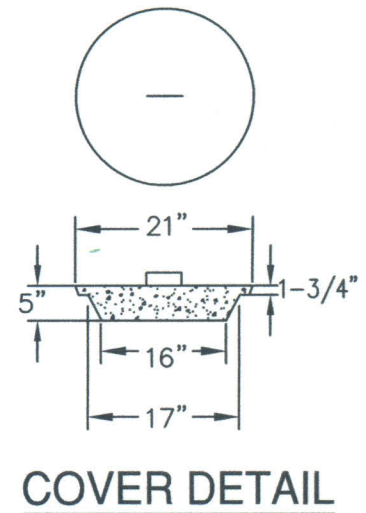
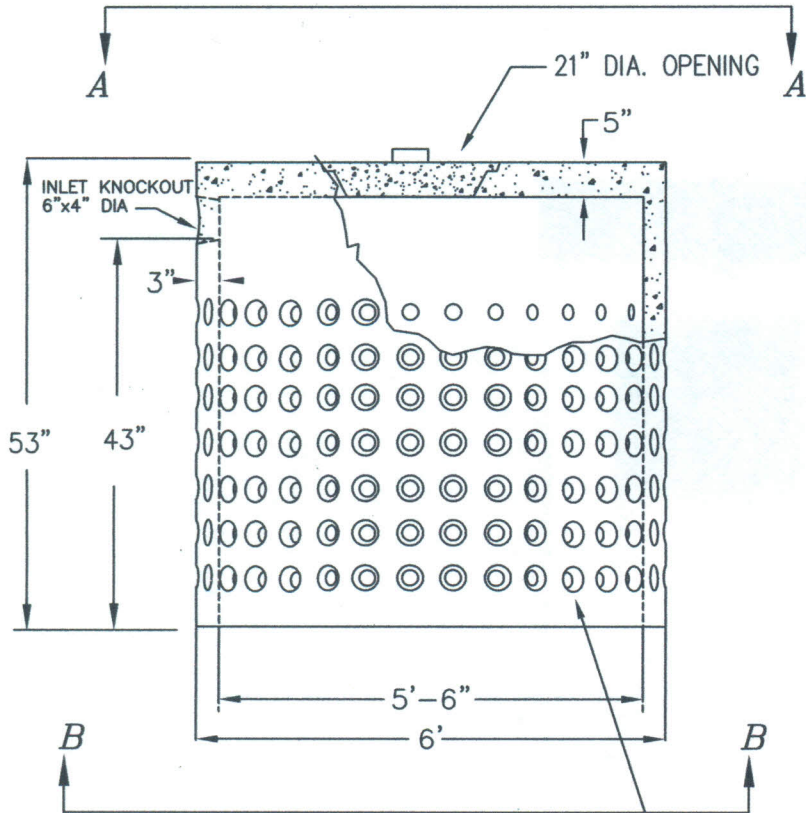

216 4-1/2"x2" DIA
LEACHING HOLES
6"x6" ON CENTER

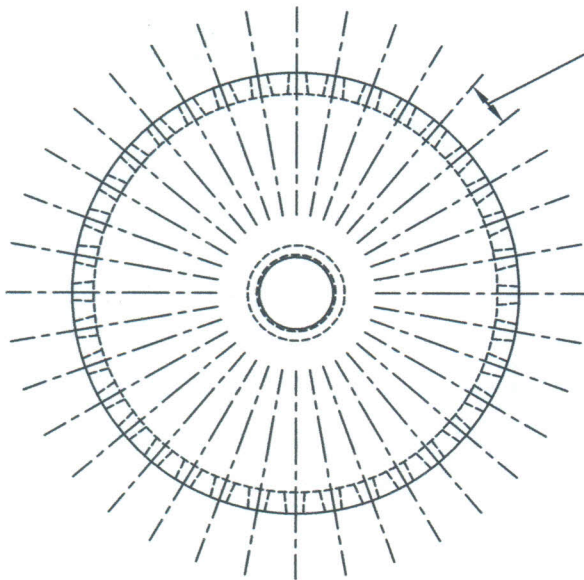

SECTION B-B

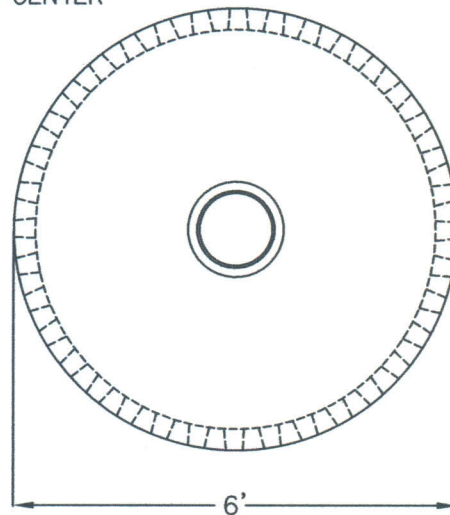

SECTION A-A

SPECIFICATIONS

- 1.) CONCRETE STRENGTH F'C 4,000 PSI @ 28 DAYS.
- 2.) CEMENT, PORTLAND TYPE I OR III. ASTM C150-81.
- 3.) ADMIXTURES, AIR & PLASTICIZERS @ ASTM C233-82.
- 4.) STEEL REINFORCEMENT 6"x6" 10 GA. STEEL WIRE MESH.

Weight 3900 #