



WIGGIN MEANS PRECAST CO., INC.

P.O. BOX 1507 POCASSET, MASSACHUSETTS 02559

TEL: 508.564.6776 FAX: 508.564.6770

www.wigginprecast.com

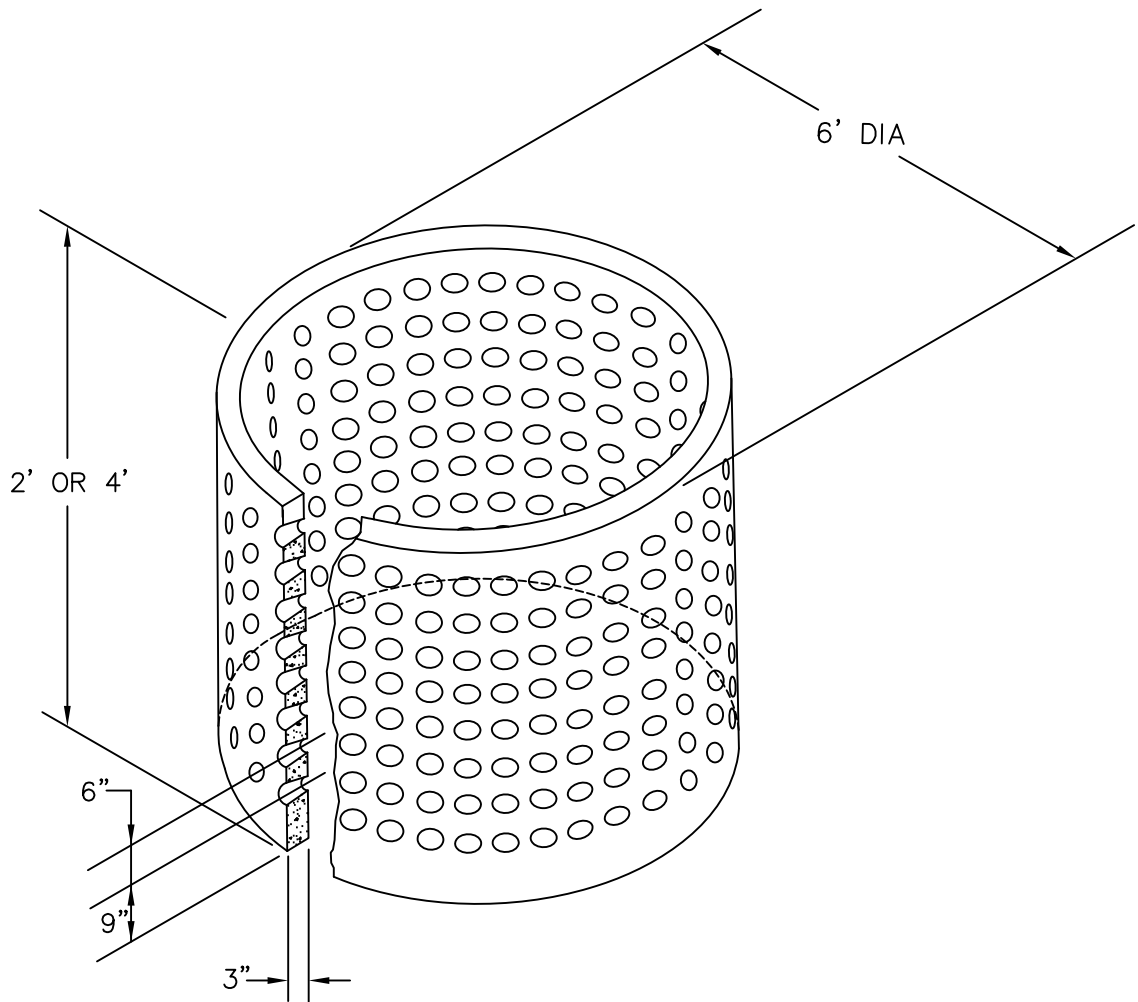

LEACHING PIT 2' AND 4' SECTIONS

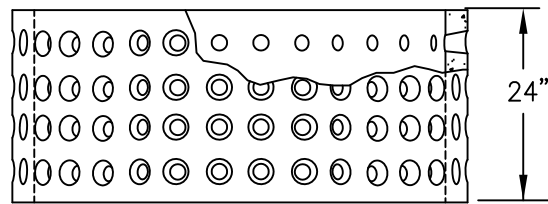
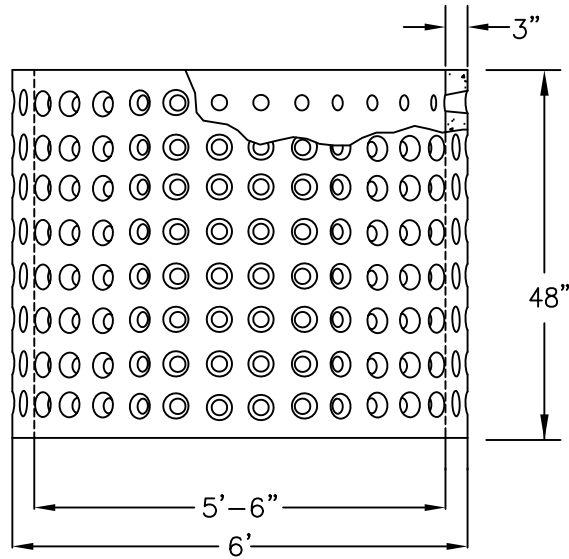

SPECIFICATIONS

- 1.) CONCRETE STRENGTH F'C 5,000 PSI @ 28 DAYS.
- 2.) CEMENT, PORTLAND TYPE I OR III. ASTM C150-81.
- 3.) ADMIXTURES, AIR & PLASTICIZERS @ ASTM C233-82.
- 4.) STEEL REINFORCEMENT 6"x6" 10 GA. STEEL WIRE MESH.
- 5.) WEIGHT 2' SHIM 1099 LBS, 4' SHIM 2199 LBS