



# WIGGIN MEANS PRECAST CO., INC.

P.O. BOX 1507 POCASSET, MASSACHUSETTS 02559

TEL: 508.564.6776 FAX: 508.564.6770

[www.wigginprecast.com](http://www.wigginprecast.com)

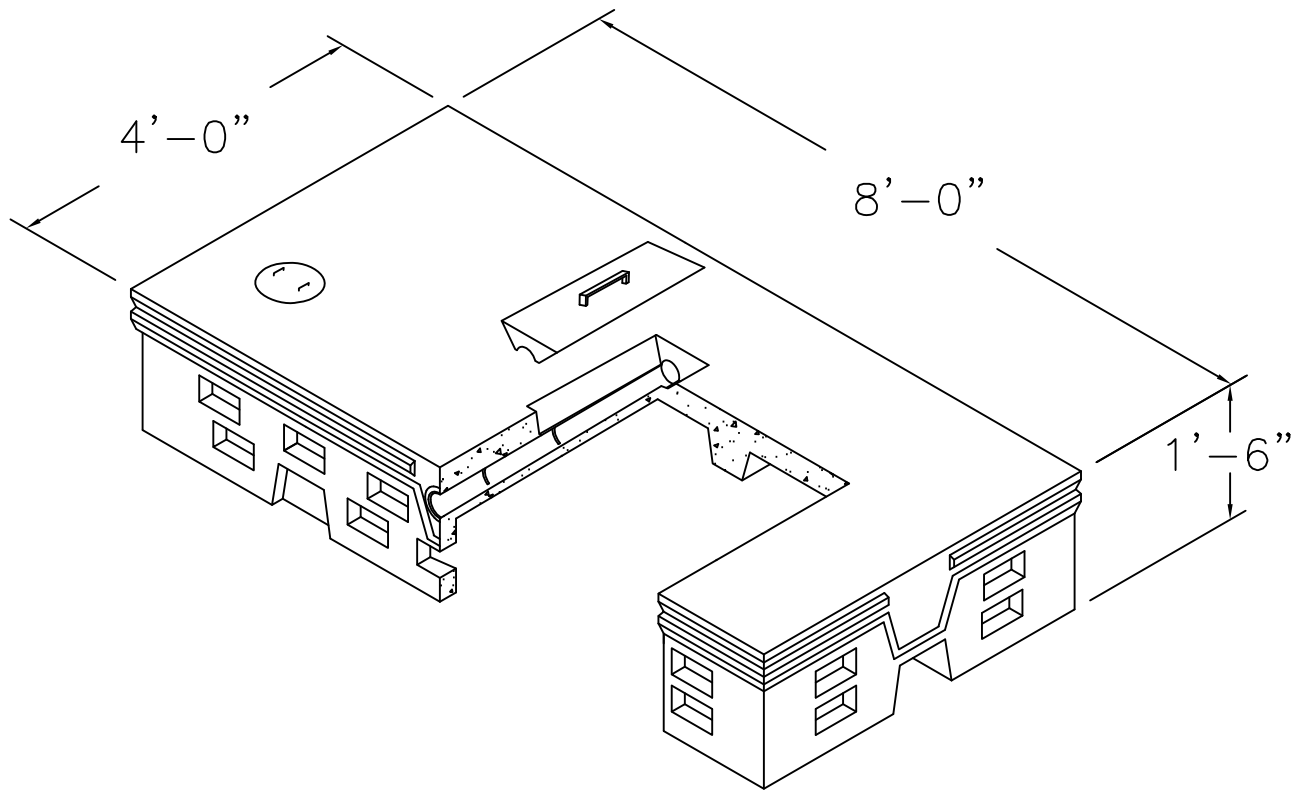

## LEACHING CHAMBER 4 x 8 " S" FLOWDIFFUSOR

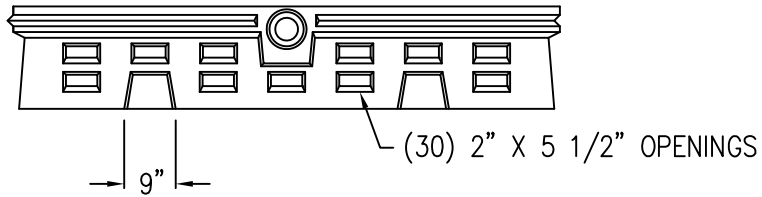

**FRONT VIEW**

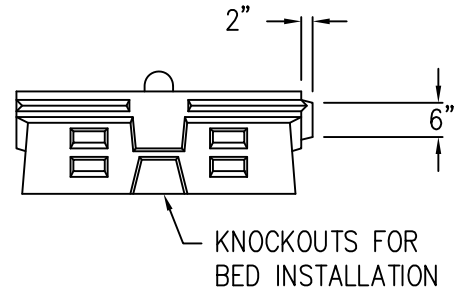

**SIDE VIEW**

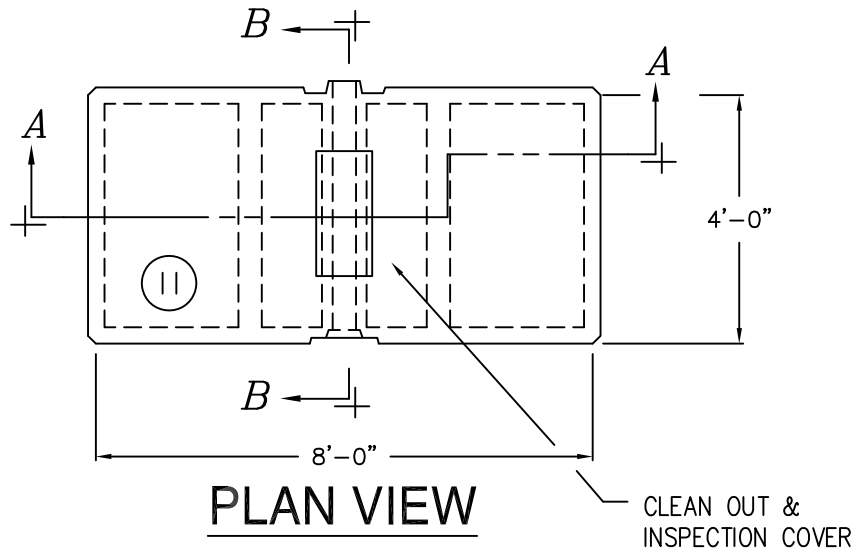

**PLAN VIEW**

CLEAN OUT &  
INSPECTION COVER

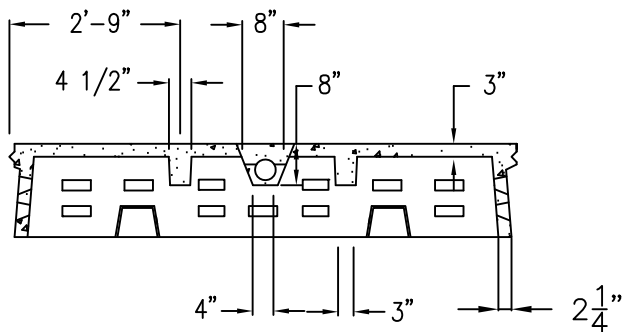

**SECTION A-A**

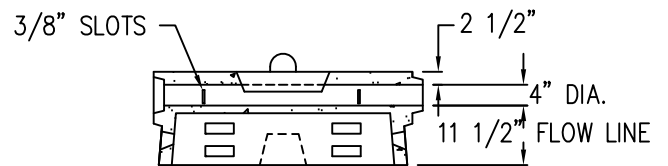

**SECTION B-B**

**SPECIFICATIONS**

- 1.) CONCRETE STRENGTH 5,000 PSI @ 28 DAYS.
- 2.) CEMENT, PORTLAND TYPE I OR III. ASTM C150-81.
- 3.) REINFORCING ASTM A615 FOR WIRE FABRIC, GRADE 60 BAR.
- 4.) DESIGN LOADING AASHTO HS20-44.
- 5.) WEIGHT 2,027 LBS.