



WIGGIN MEANS PRECAST CO., INC.

P.O. BOX 1507 POCASSET, MASSACHUSETTS 02559

TEL: 508.564.6776 FAX: 508.564.6770

www.wigginprecast.com

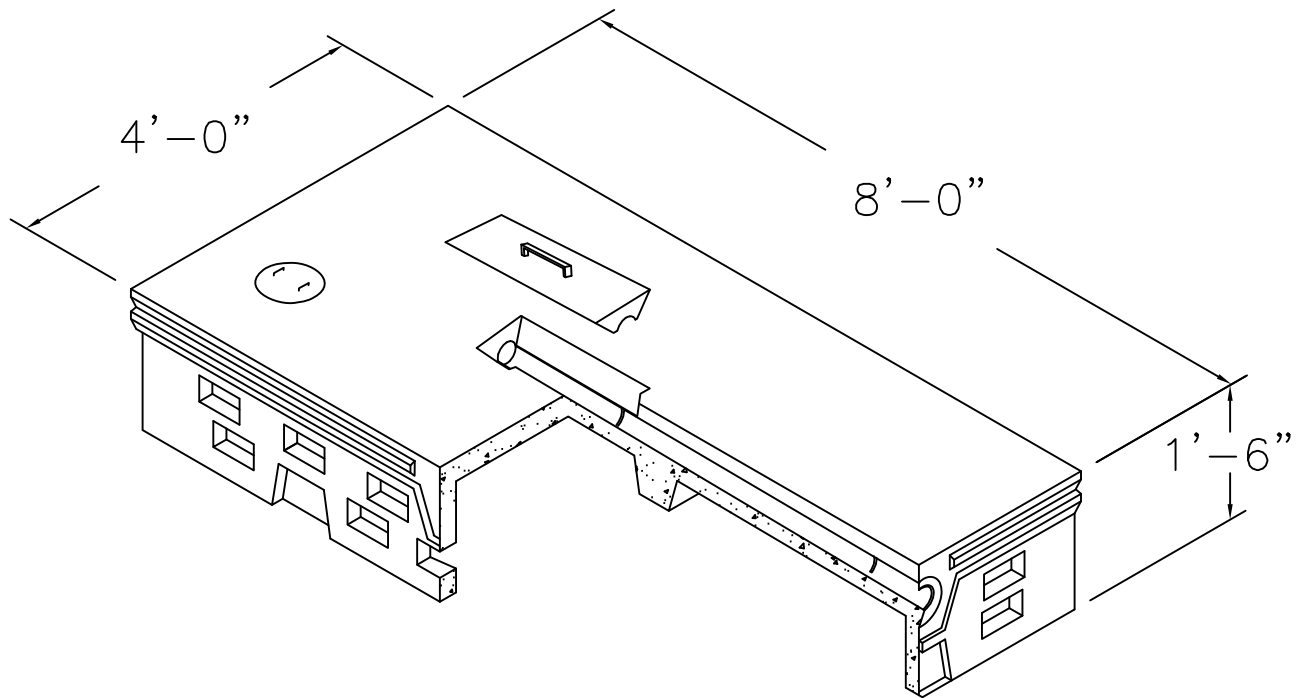

LEACHING CHAMBER 4 x 8 "L" FLOWDIFFUSOR

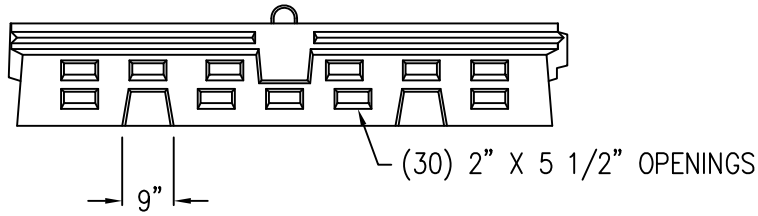

FRONT VIEW

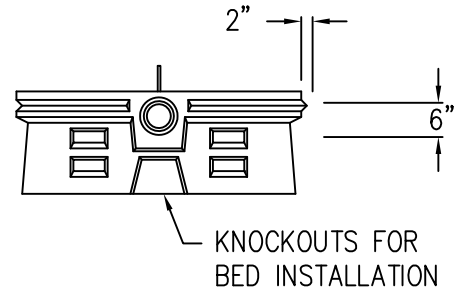

SIDE VIEW

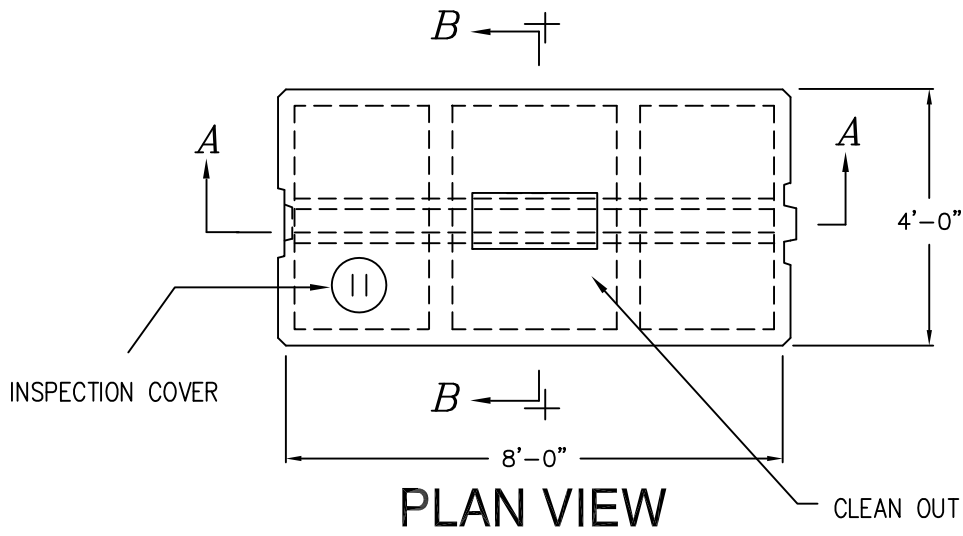

PLAN VIEW

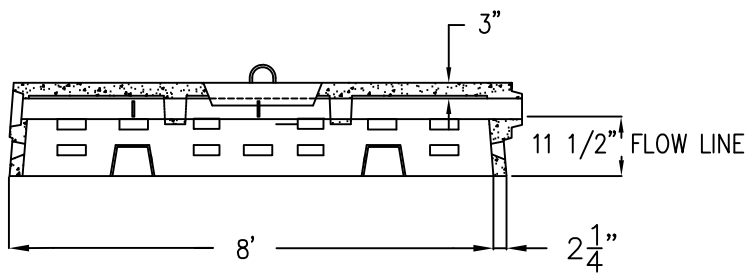

SECTION A-A

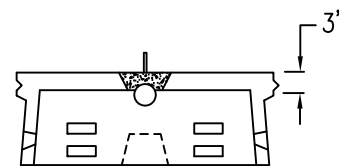

SECTION B-B

SPECIFICATIONS

- 1.) CONCRETE STRENGTH F'C 5,000 PSI @ 28 DAYS. DENSITY 150 PCF.
- 2.) CEMENT, PORTLAND TYPE I OR III. ASTM C150-81.
- 3.) ADMIXTURES, AIR & PLASTICIZERS @ ASTM C233-82.
- 4.) REINFORCING ASTM A615 FOR WIRE FABRIC, GRADE 60 BAR.
- 5.) DESIGN LOADING AASHTO HS20-44.
- 6.) WEIGHT 2027 LBS.