



WIGGIN MEANS PRECAST CO., INC.

P.O. BOX 1507 POCASSET, MASSACHUSETTS 02559

TEL: 508.564.6776 FAX: 508.564.6770

www.wigginprecast.com

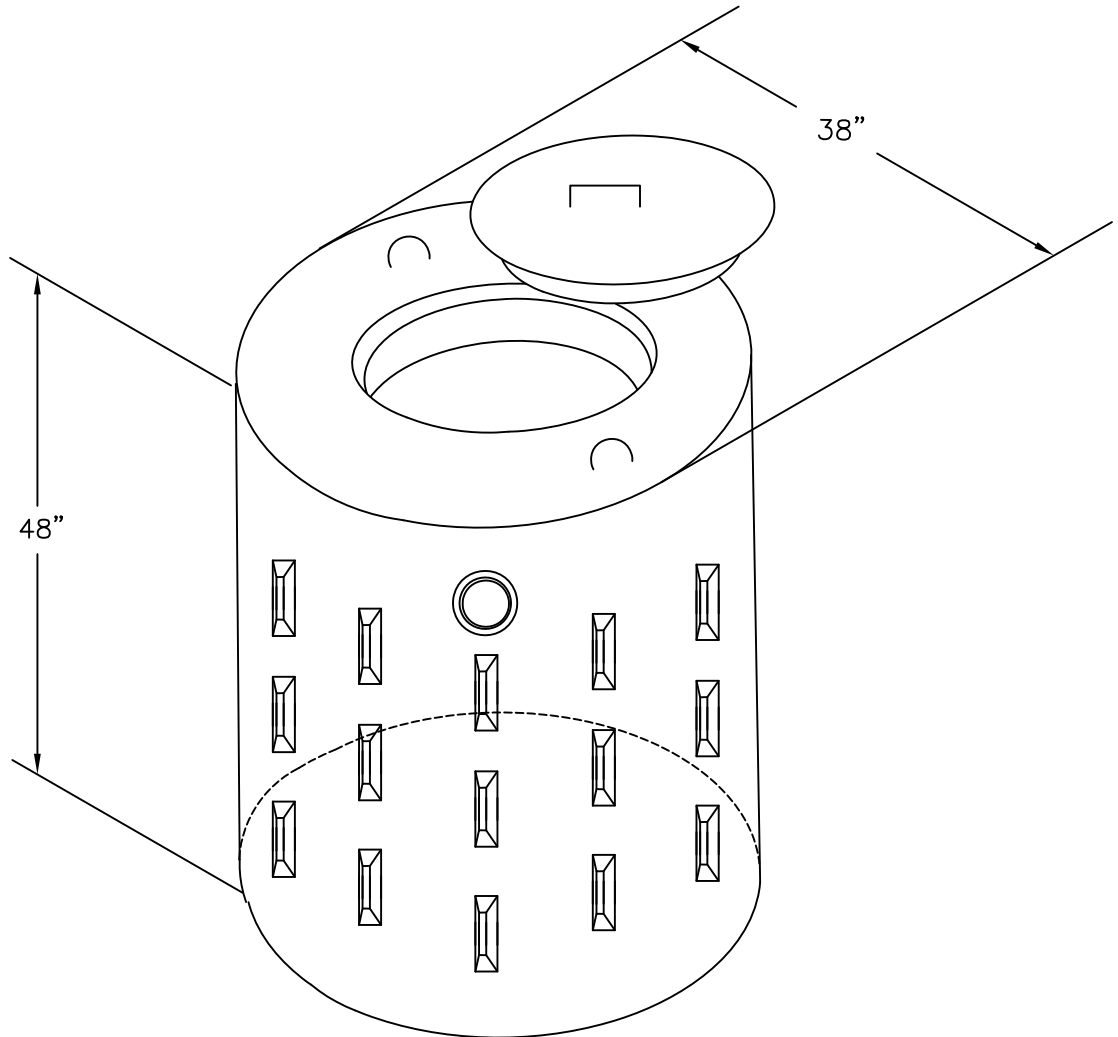

100 GALLON
DRYWELL

H-20

2-POLYLOK PIPE SEALS
OPPOSITE 180 DEGREES

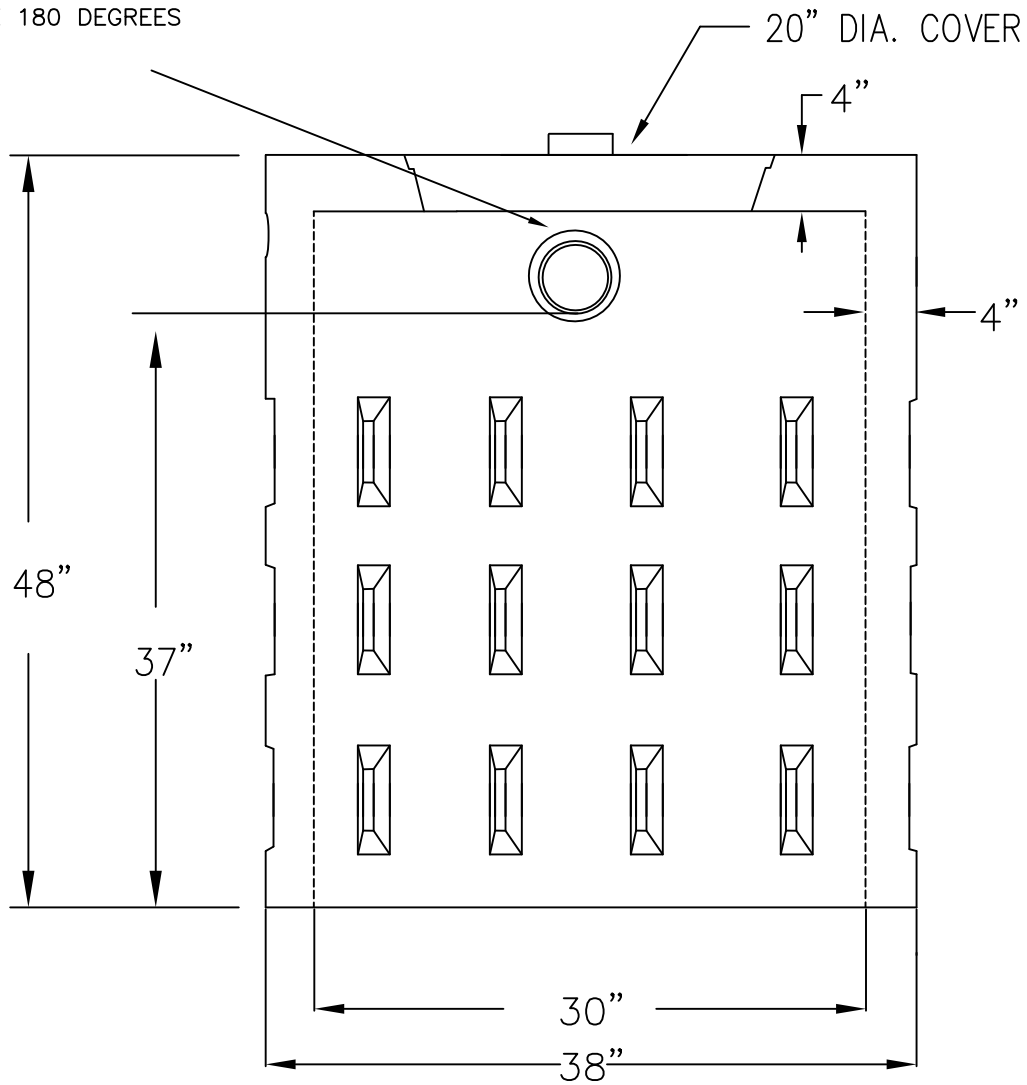

SPECIFICATIONS

- 1.) CONCRETE STRENGTH F'C 5,000 PSI @ 28 DAYS.
- 2.) CEMENT, PORTLAND TYPE I OR III. ASTM C150-81.
- 3.) DESIGN LOADING PER AASHO HS-20
- 4.) STEEL REINFORCEMENT PER ASTM A-615 GRADE 60
- 5.) WEIGHT 1700 LBS.