



WIGGIN MEANS PRECAST CO., INC.

P.O. BOX 1507 POCASSET, MASSACHUSETTS 02559

TEL: 508.564.6776 FAX: 508.564.6770

www.wigginprecast.com

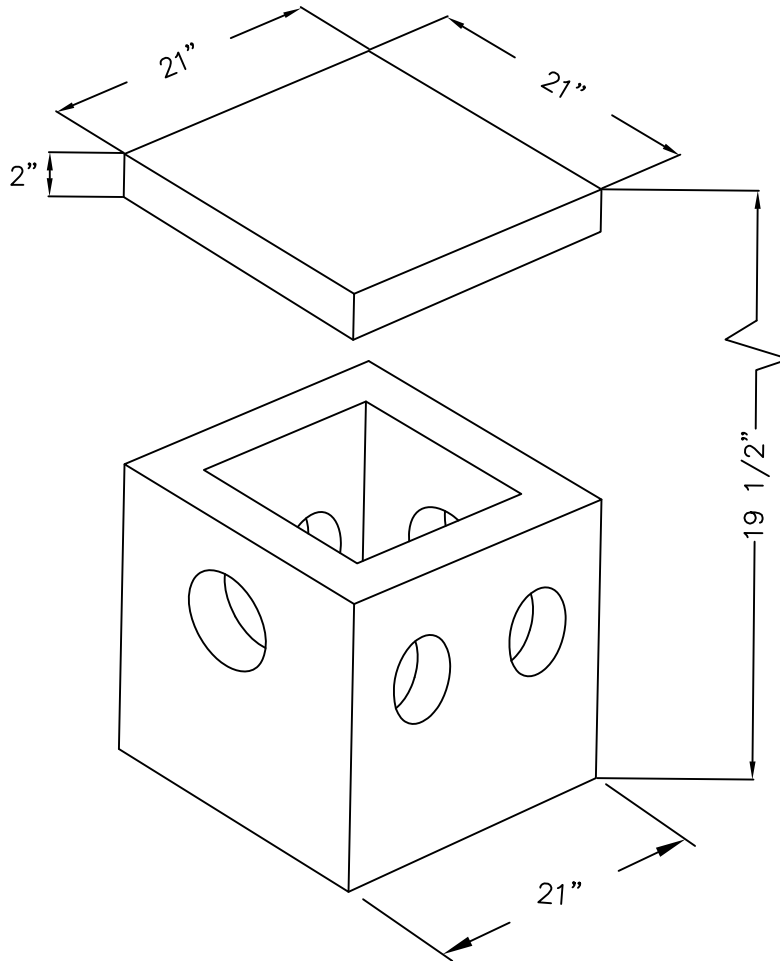

DB-6
DISTRIBUTION BOX: 6 OUTLET

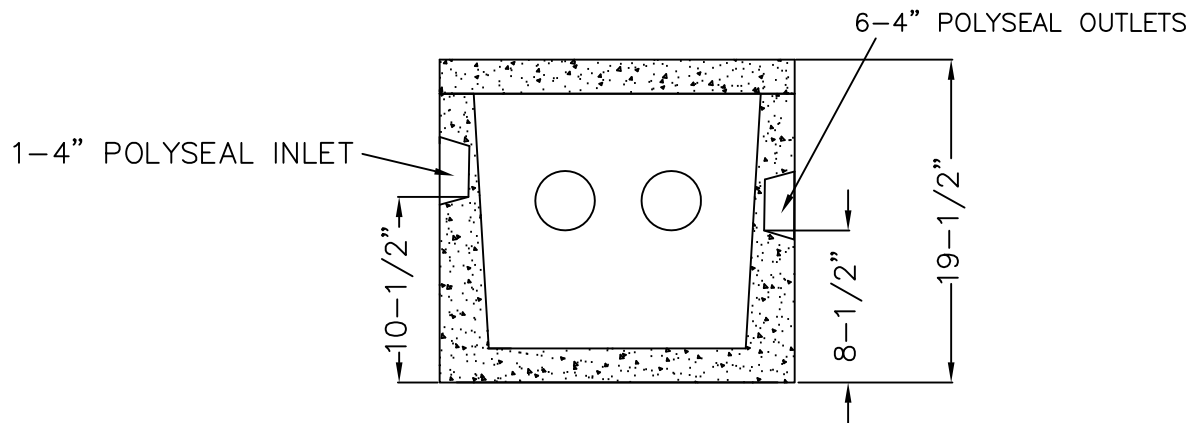
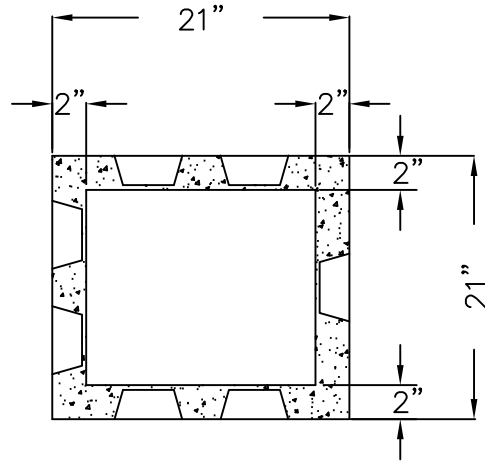

SPECIFICATIONS

- 1.) CONCRETE STRENGTH 4,000 PSI @ 28 DAYS.
- 2.) CEMENT, PORTLAND TYPE II PER ASTM C150-81
- 3.) STEEL REINFORCEMENT PER ASTM A-615. GRADE 60.
- 4.) DESIGN LOADING PER AASHTO HS-10.
- 5.) 8" & 15" RISER SECTIONS AVAILABLE, RISER BASE AVAILABLE
- 6) WEIGHT 255 LBS