

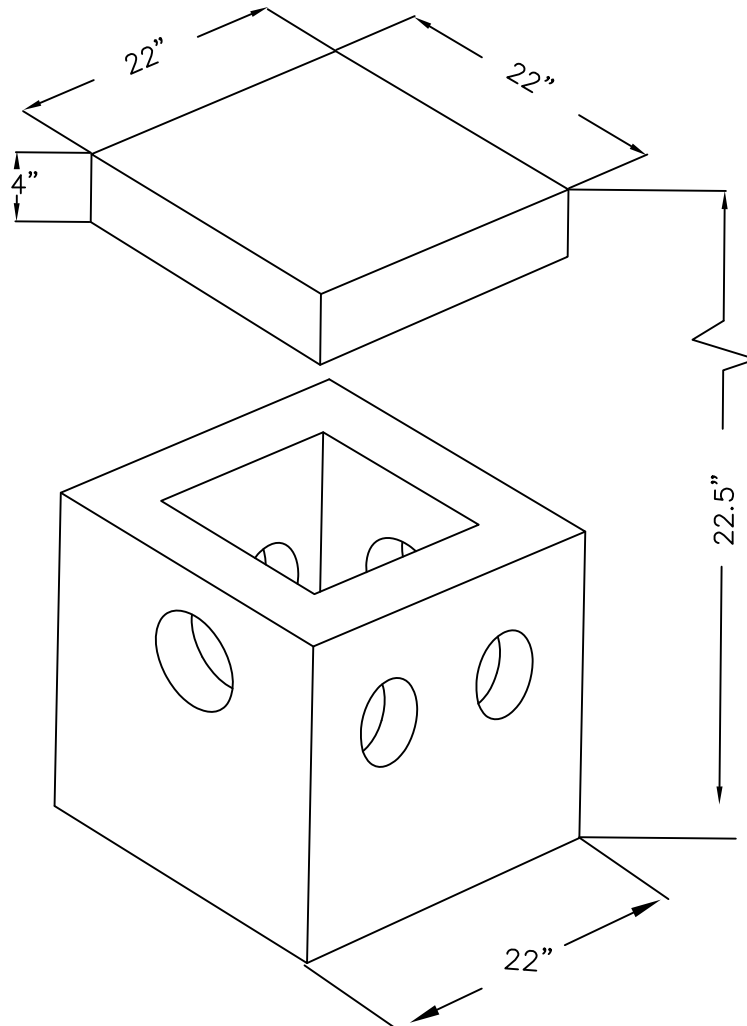

WIGGIN MEANS PRECAST CO., INC.

P.O. BOX 1507 POCASSET, MASSACHUSETTS 02559
TEL: 508.564.6776 FAX: 508.564.6770
www.wigginprecast.com



DB-5 H-20
DISTRIBUTION BOX: 5 OUTLET H-20

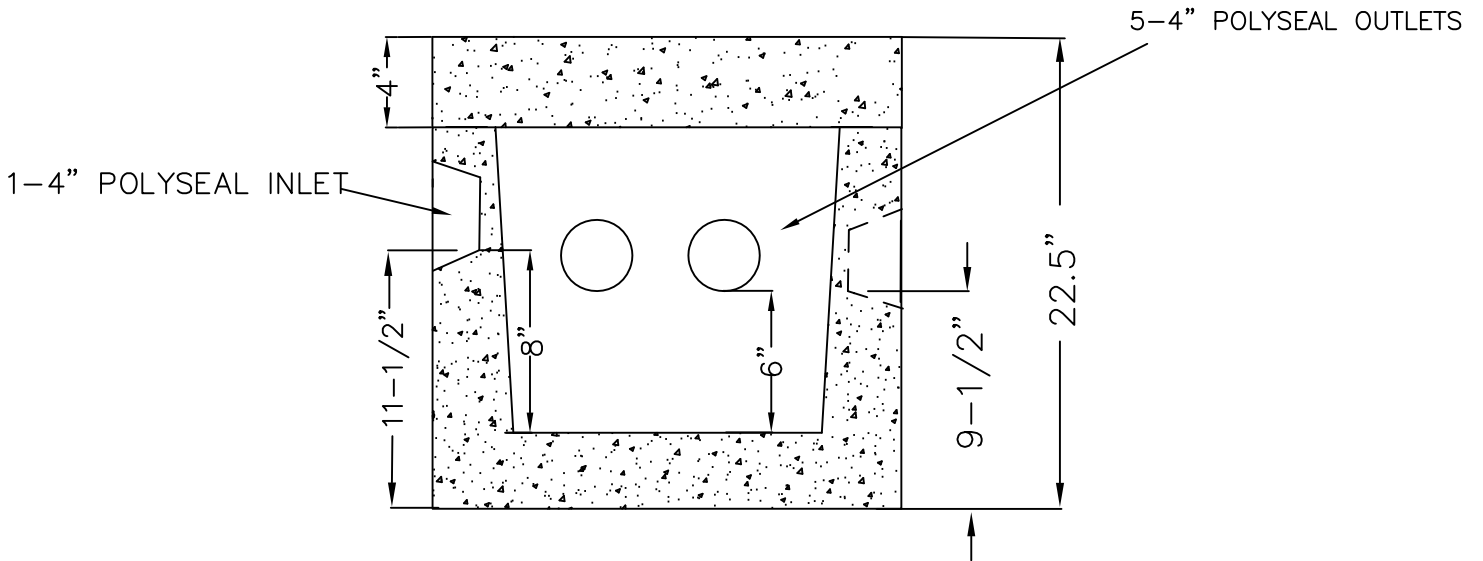
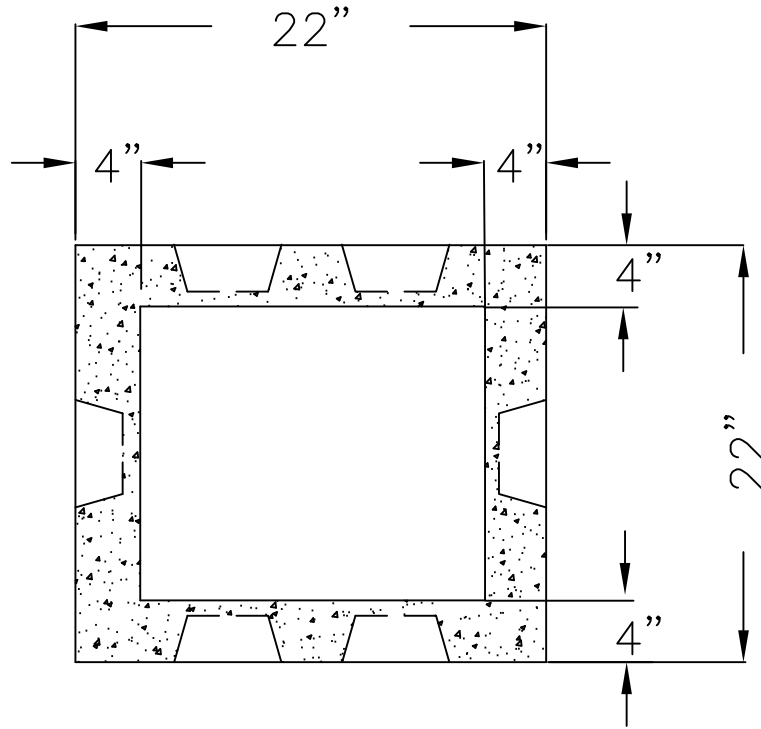

SPECIFICATIONS

- 1.) CONCRETE STRENGTH 5,000 PSI @ 28 DAYS.
- 2.) CEMENT, PORTLAND TYPE II PER ASTM C150-81
- 3.) REINFORCEMENT PER ASTM C1227-93
- 4.) 8" & 15" RISER SECTIONS AVAILABLE
- 5.) WEIGHT 530 LBS