



WIGGIN MEANS PRECAST CO., INC.

P.O. BOX 1507 POCASSET, MASSACHUSETTS 02559

TEL: 508.564.6776 FAX: 508.564.6770

www.wigginprecast.com

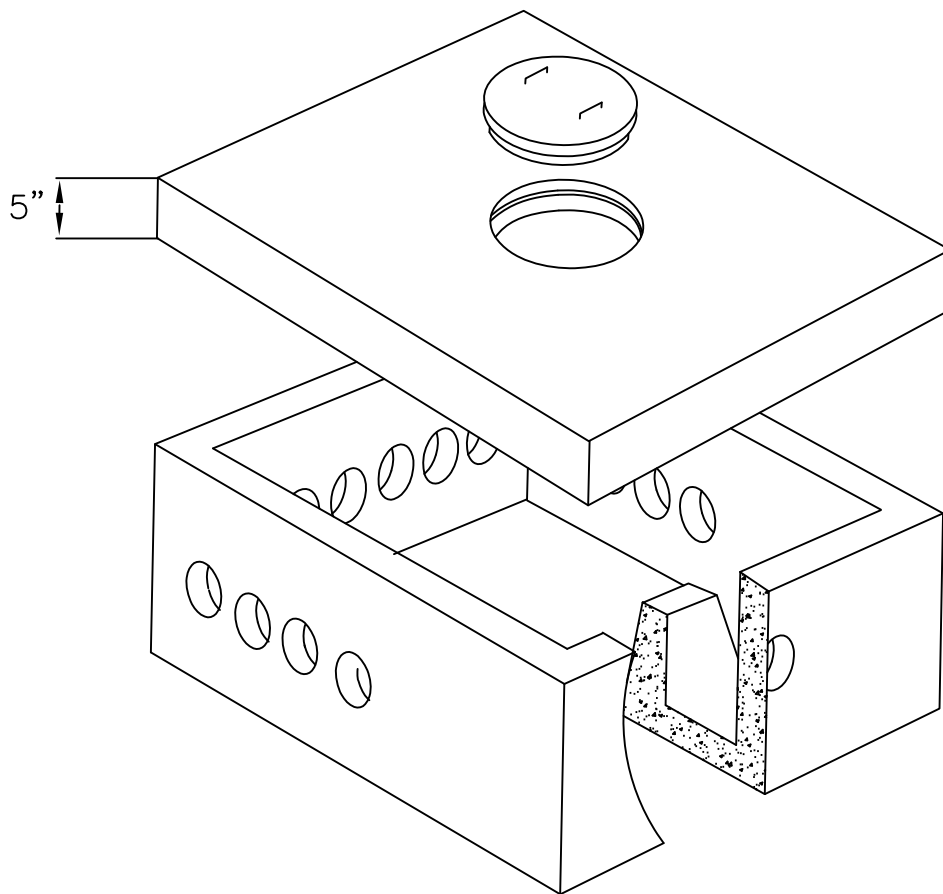

DB-14
DISTRIBUTION BOX: 14 OUTLET

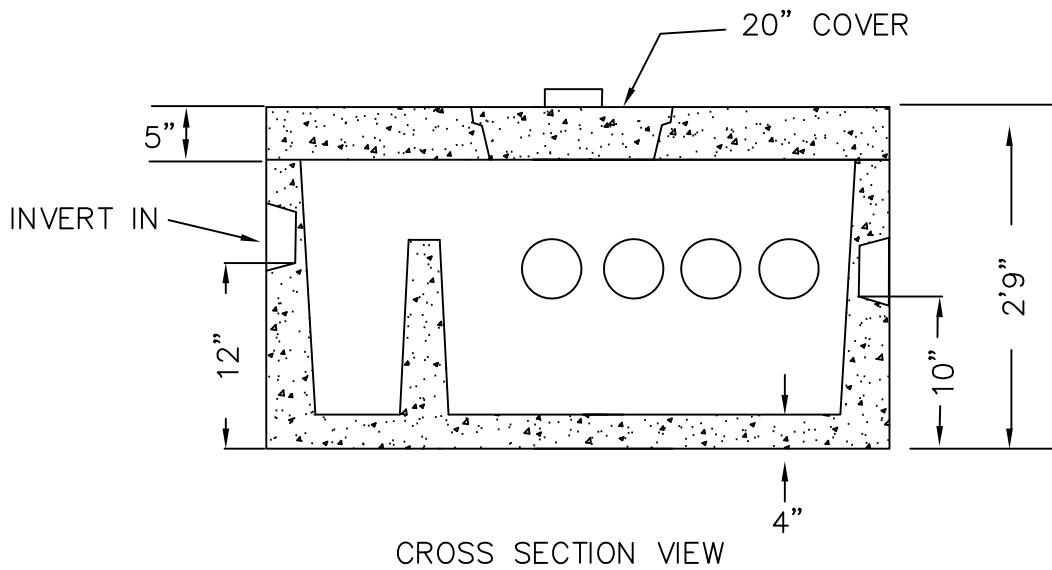
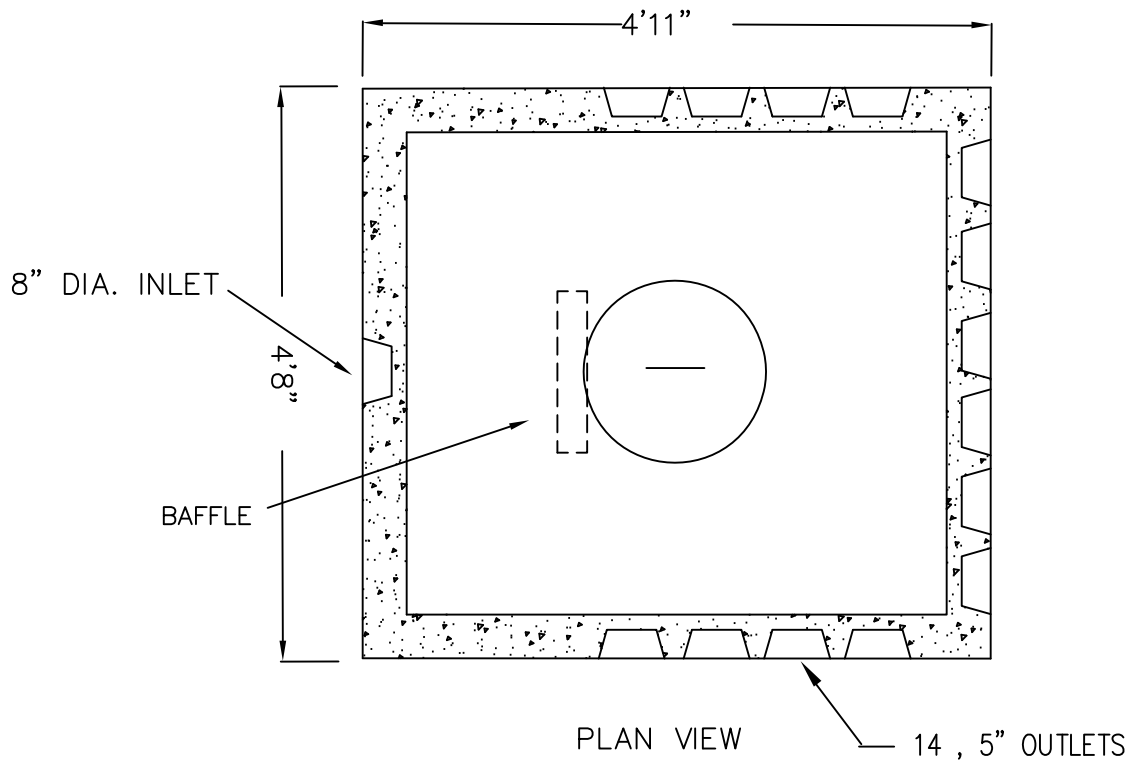

SPECIFICATIONS

- 1.) CONCRETE STRENGTH 5,000 PSI @ 28 DAYS.
- 2.) CEMENT, PORTLAND TYPE II PER ASTM C150-81
- 3.) STEEL REINFORCEMENT PER ASTM A-615. GRADE 60.
- 4.) DESIGN LOADING PER AASHTO HS-20.
- 5.) WEIGHT 2784 LBS