

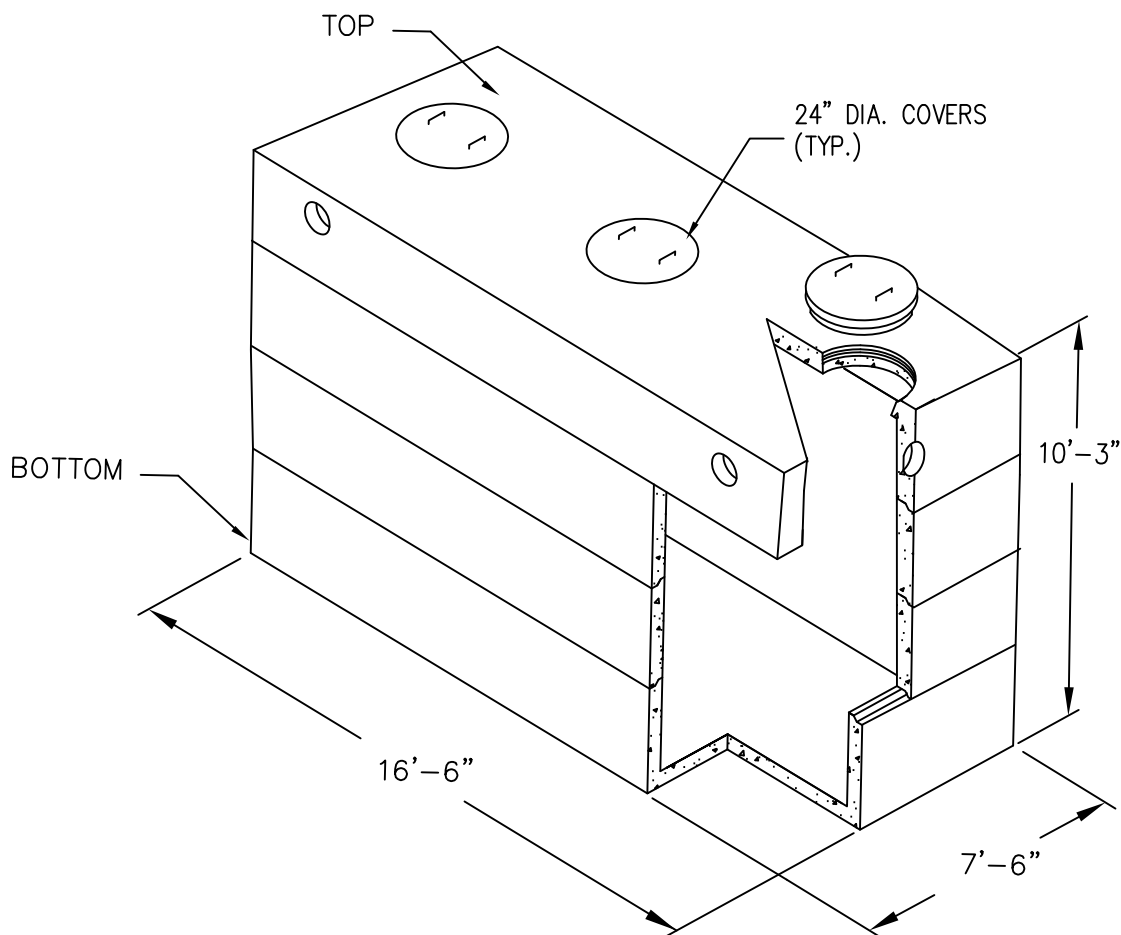

# WIGGIN MEANS PRECAST CO. INC.

P.O. BOX 1138 POCASSET, MASSACHUSETTS 02559  
TEL: 508.564.6776 FAX: 508.564.6770  
[www.wigginprecast.com](http://www.wigginprecast.com)



**6,000 GALLON  
PRECAST SEPTIC TANK/H<sub>2</sub>O  
AVAILABLE IN 2 or 3 COMPARTMENT**

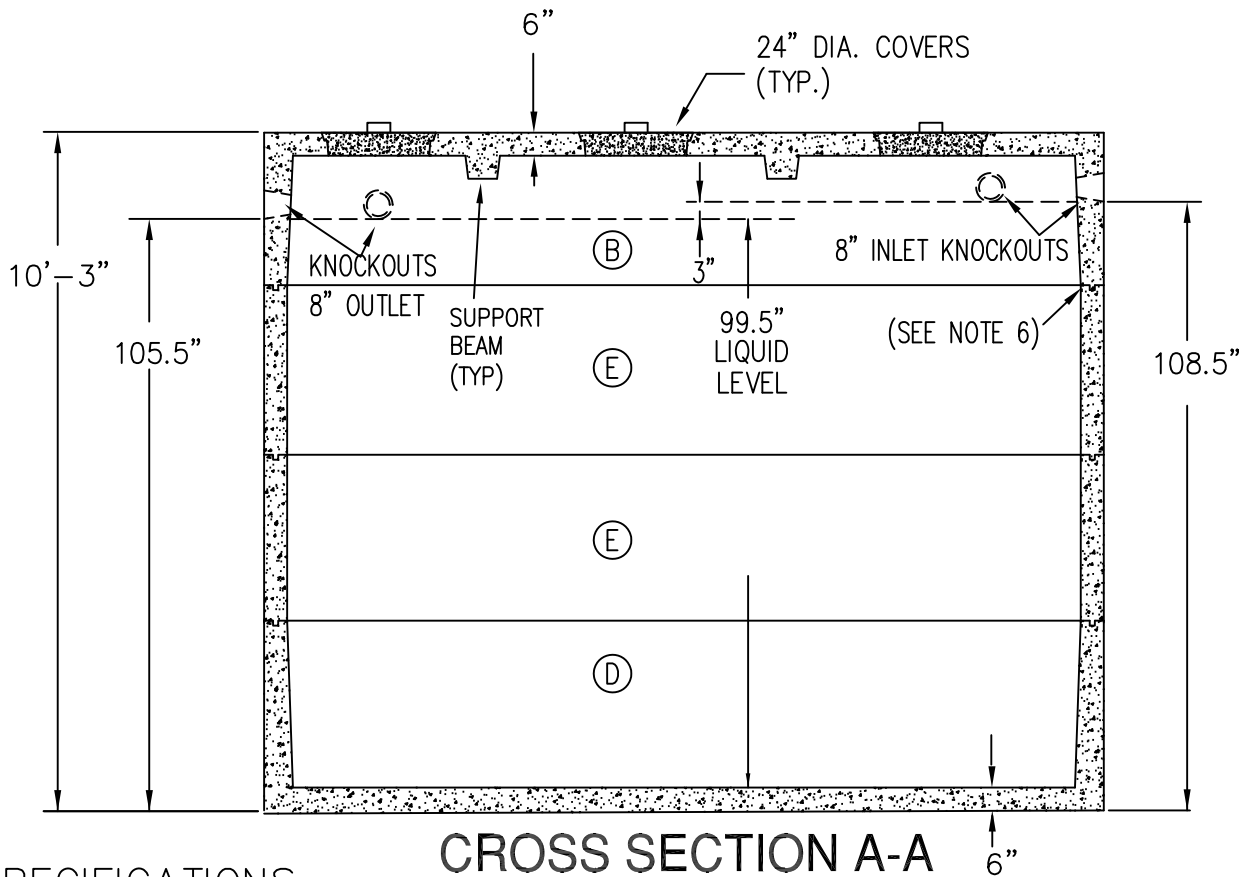
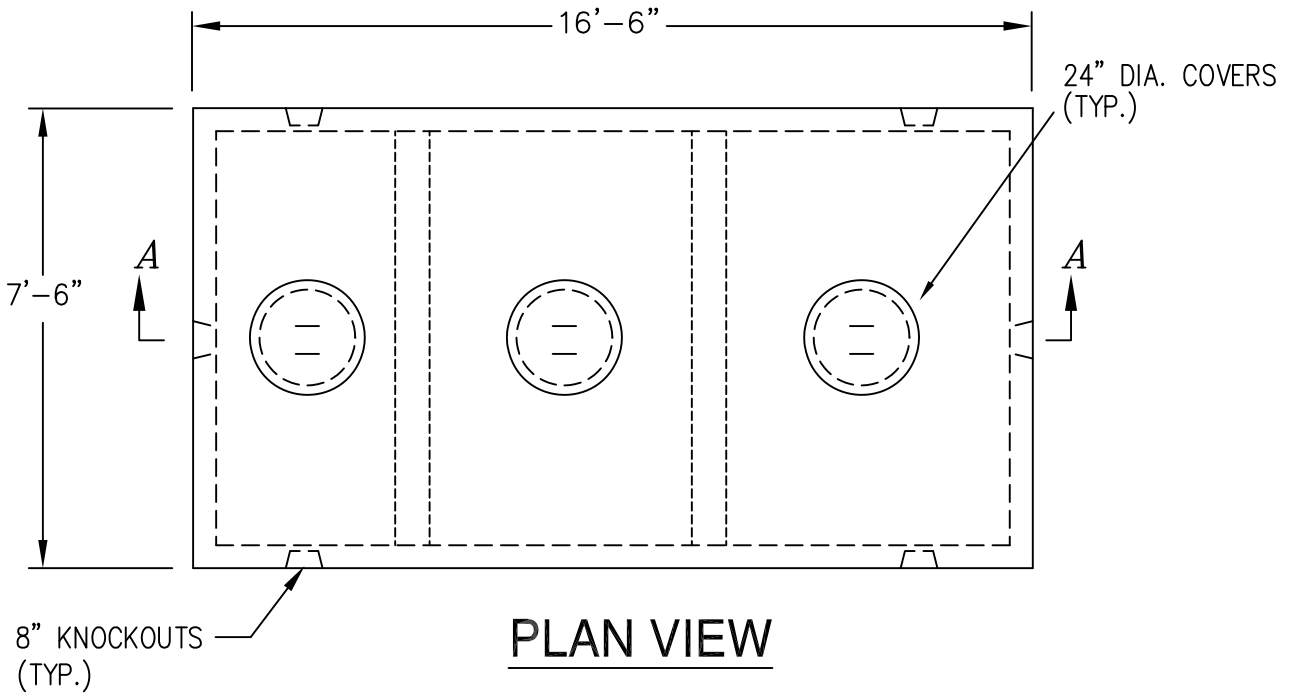

**SPECIFICATIONS**

- 1.) CONCRETE STRENGTH F'C 5,000 PSI @ 28 DAYS. DENSITY 150 PCF.
- 2.) CEMENT, PORTLAND TYPE I OR III. ASTM C150-81.
- 3.) ADMIXTURES, AIR & PLASTICIZERS @ ASTM C233-82.
- 4.) REINFORCING ASTM A615 FOR WIRE FABRIC, GRADE 60 BAR.
- 5.) DESIGN LOADING AASHTO HS20-44. - WEIGHT 50,380 LBS
- 6.) CONSTRUCTION JOINTS SEALED WITH BUTYL RUBBER. 50,380#