



# WIGGIN MEANS PRECAST CO., INC.

P.O. BOX 1507 POCASSET, MASSACHUSETTS 02559

TEL: 508.564.6776 FAX: 508.564.6770

www.wigginprecast.com

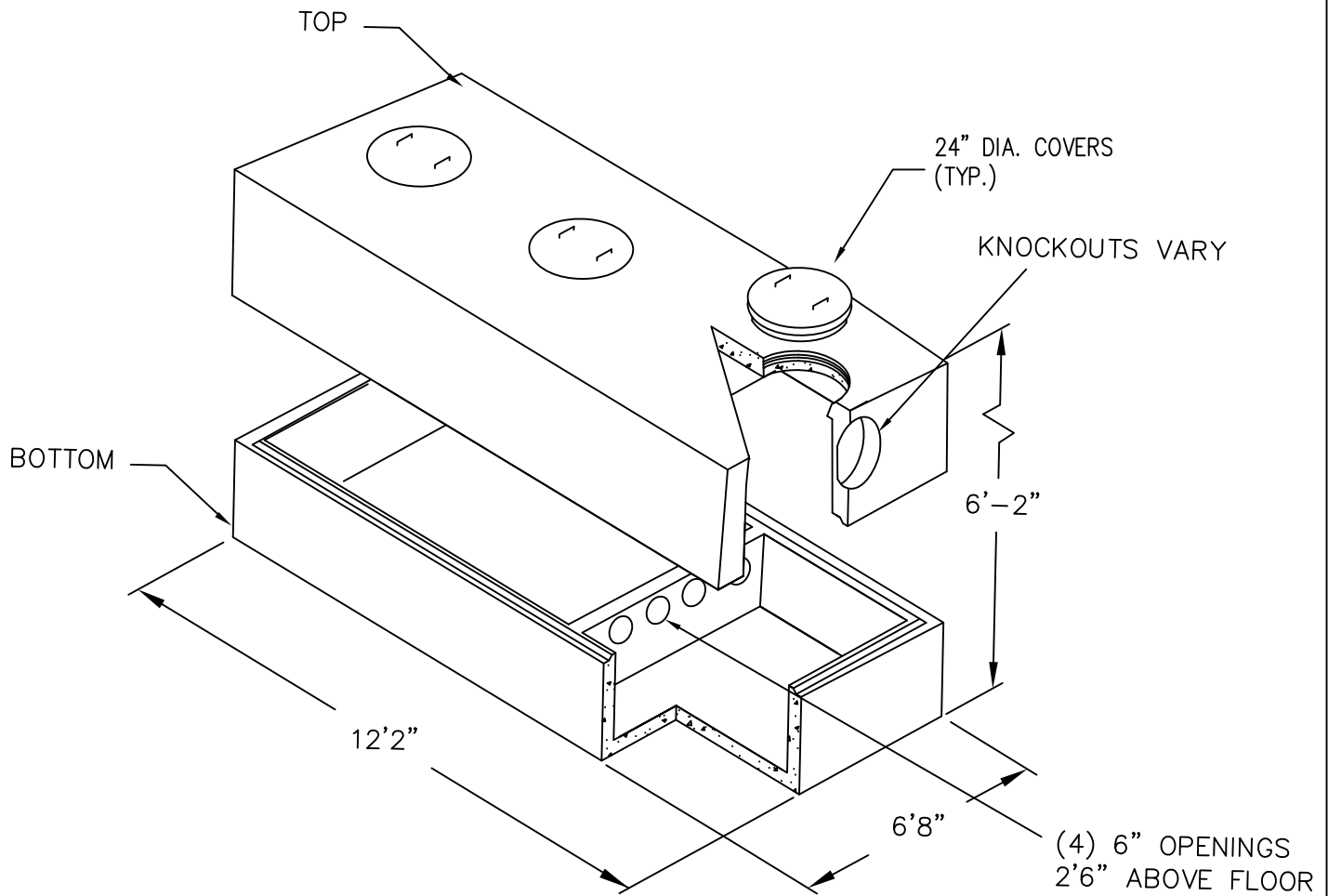

## 2000 GALLON H-20 OIL & GRIT SEPARATOR

T2000GT

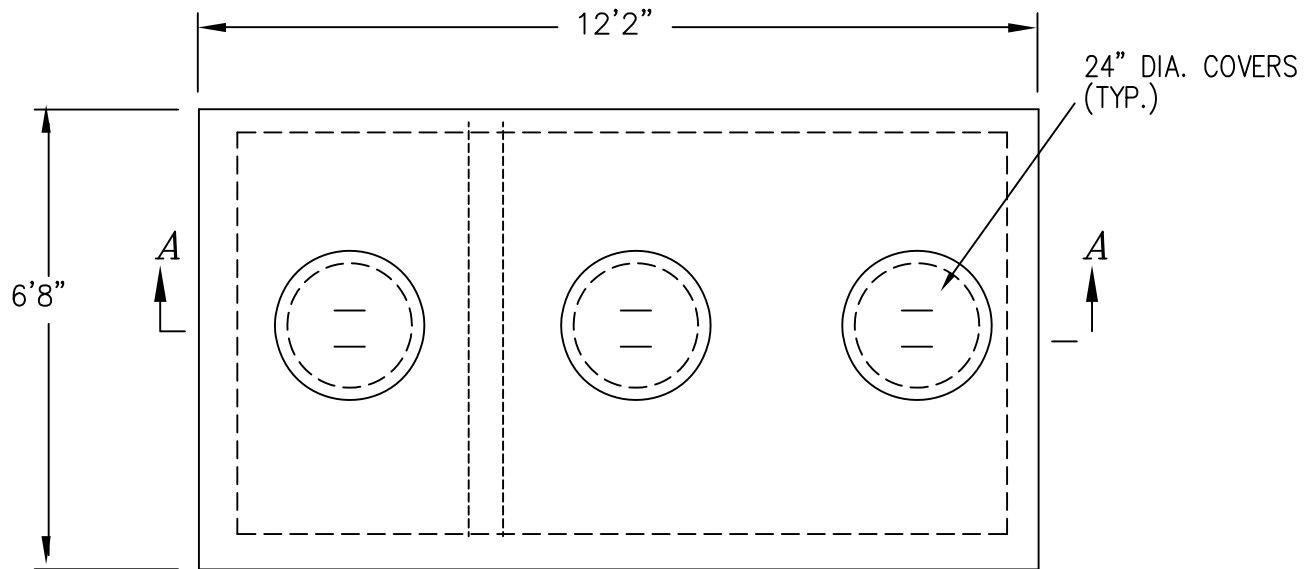

## PLAN VIEW

LEBARON L219-12 (12" PIPE )  
OIL & GREASE SEPARATOR OR EQUAL

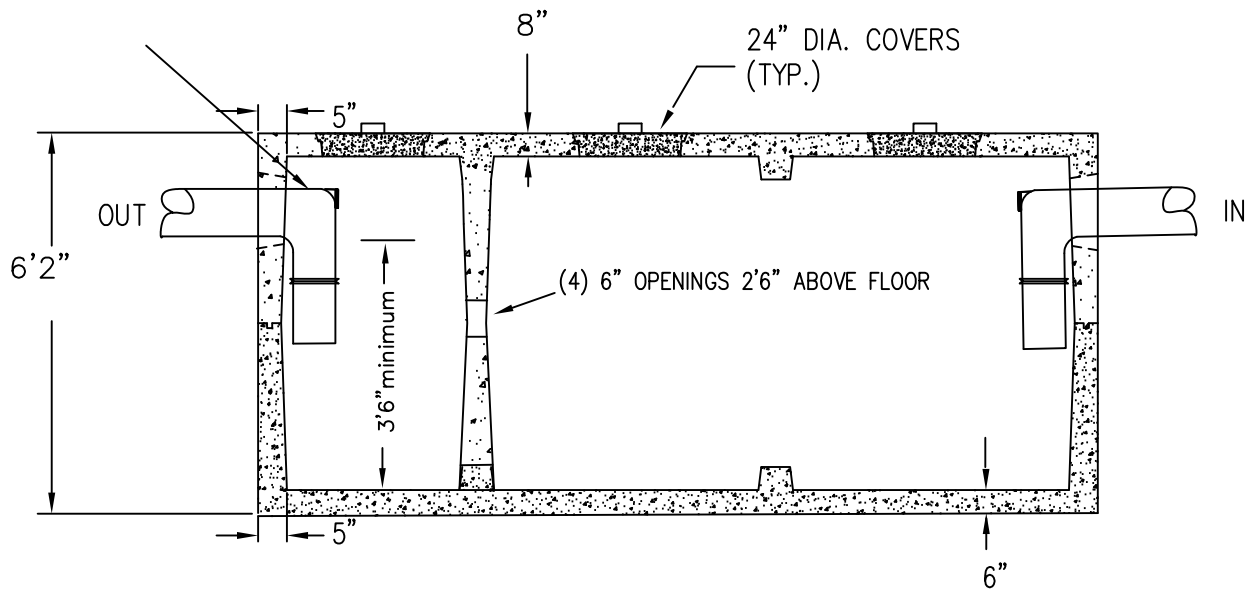

## CROSS SECTION A-A

### SPECIFICATIONS

- 1.) CONCRETE 5,000 PSI AFTER 28 DAYS.
- 2.) TONGUE & GROOVE JOINT SEALED W/ BUTYL RESIN
- 3.) DESIGN LOADING AASHTO HS20-44
- 4.) WEIGHT 24,531 LBS