



WIGGIN MEANS PRECAST CO., INC.

P.O. BOX 1507 POCASSET, MASSACHUSETTS 02559

TEL: 508.564.6776 FAX: 508.564.6770

www.wigginprecast.com

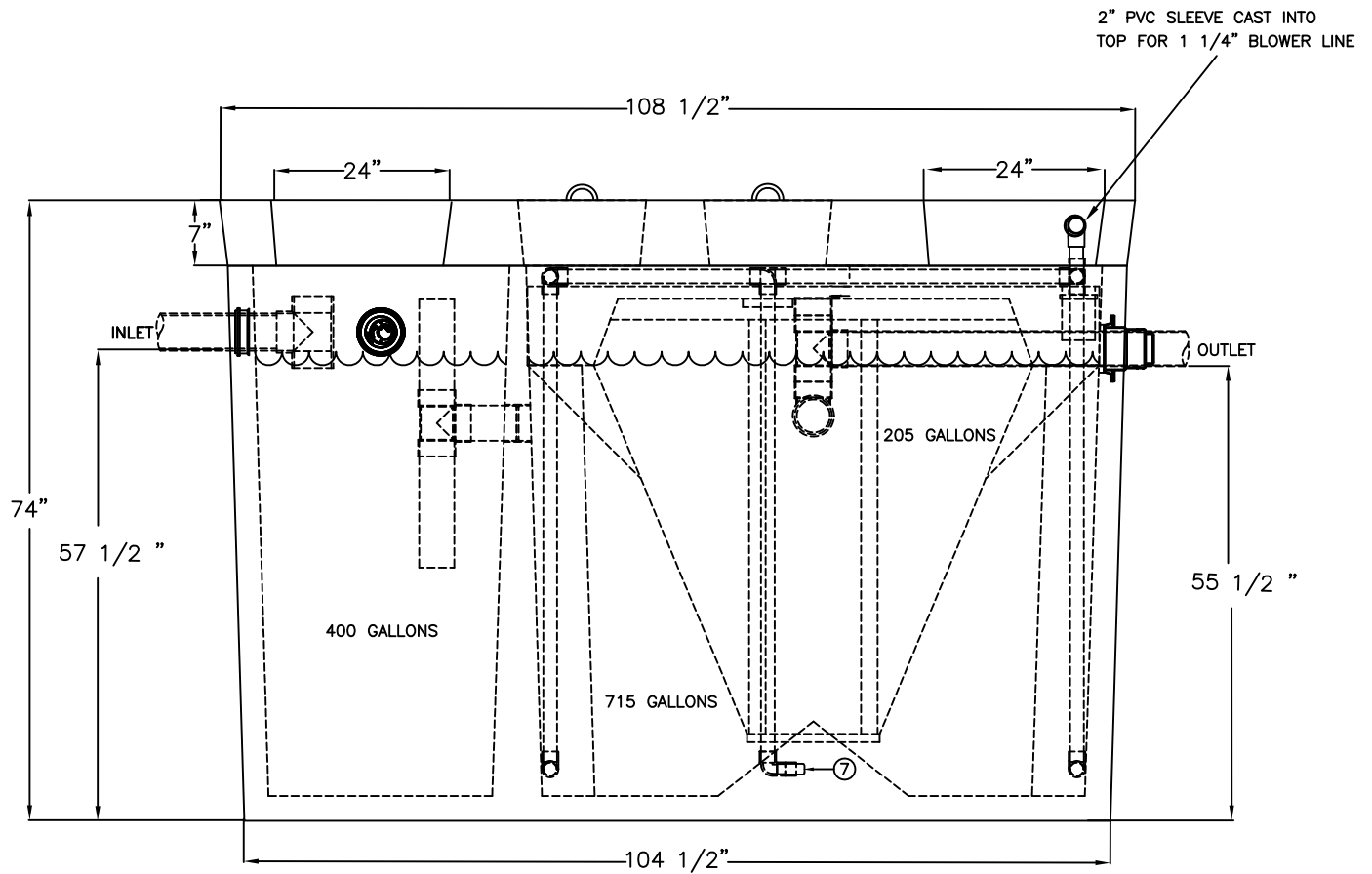

H-20 600 SERIES HOOT TANK

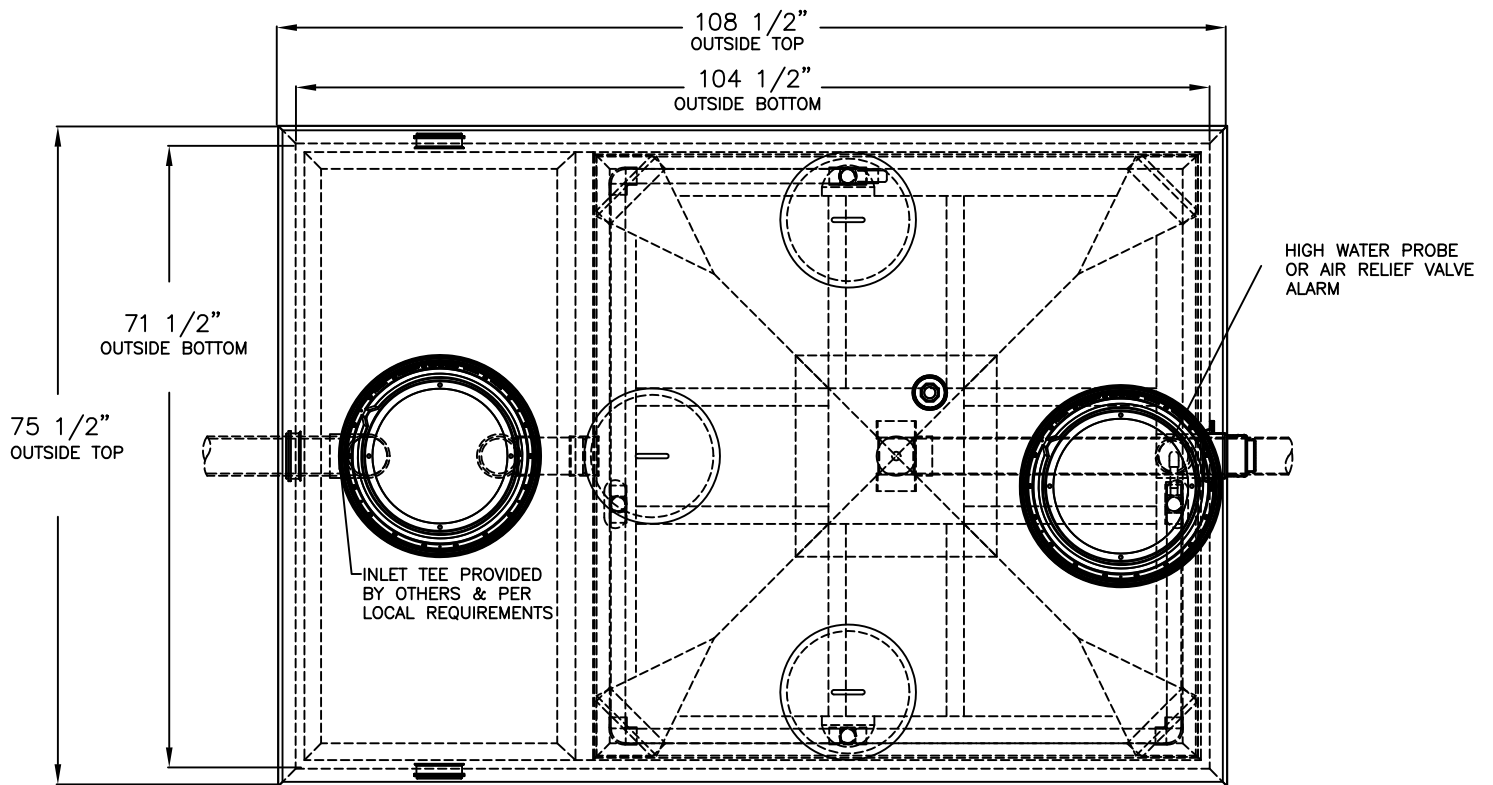

PLAN VIEW

SPECIFICATIONS

- 1.) CONCRETE 5,000 PSI AFTER 28 DAYS.
- 2.) CONSTRUCTION CONFORMS TO DEP TITLE V REGS.
310 CMR SECTION 15.226.
- 3.) REINFORCEMENT PER ASTM C1227-93.
- 4.) DESIGN LOADING AASHTO HS-20 LIVE LOAD
- 5.) APROX. WEIGHT 14,600 LBS.