



WIGGIN MEANS PRECAST CO. INC.

P.O. BOX 1507 POCASSET, MASSACHUSETTS 02559

TEL: 508.564.6776 FAX: 508.564.6770

WWW.WIGGINPRECAST.COM

E-MAIL -info@wigginprecast.com

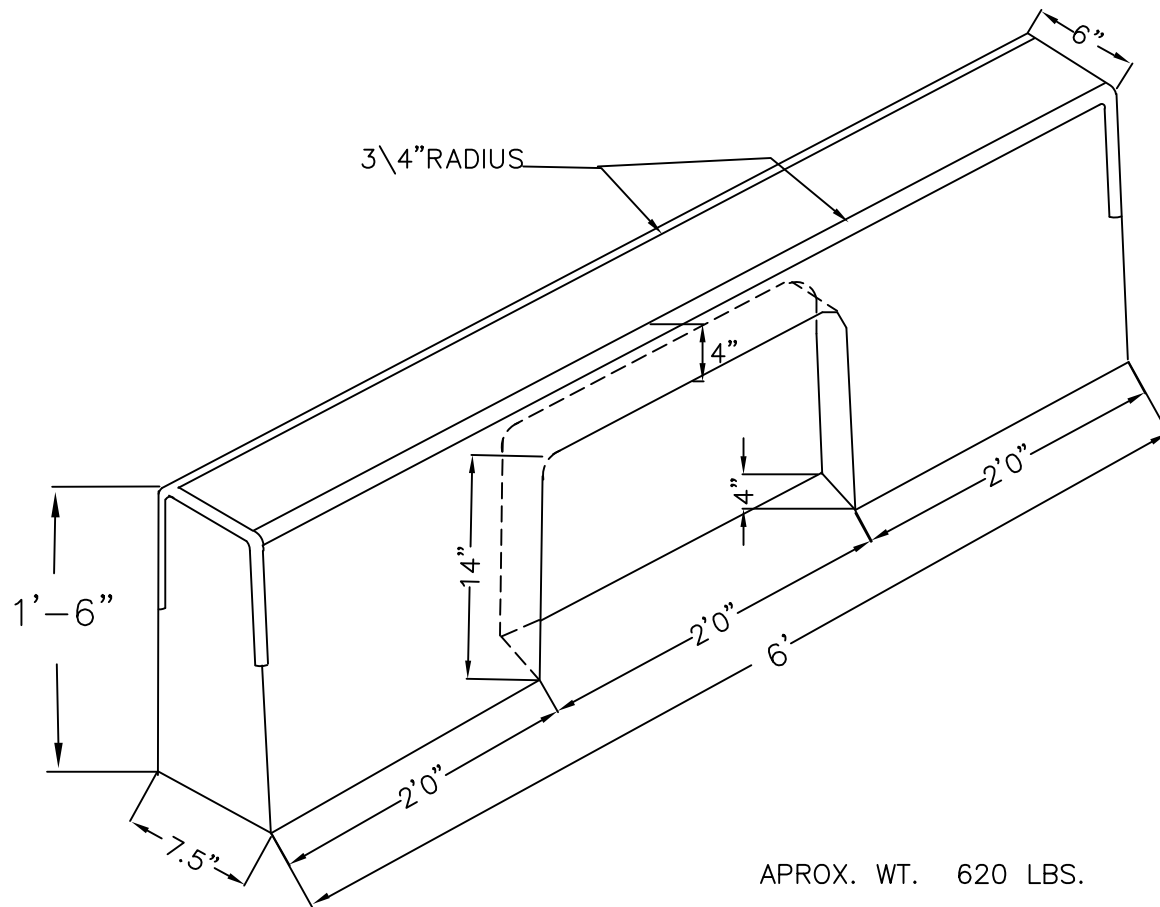

APROX. WT. 620 LBS.

18" PRECAST CONCRETE CURB INLET

SPECIFICATIONS

- 1.) CONCRETE STRENGTH F'C 5,000 PSI @ 28 DAYS. DENSITY 150 PCF.
- 2.) CEMENT, PORTLAND TYPE I OR III. ASTM C150-81.
- 3.) ADMIXTURES, AIR & PLASTICIZERS @ ASTM C233-82.